

400 SERIES TILT-WASH DOUBLE-HUNG FULL-FRAME WINDOWS

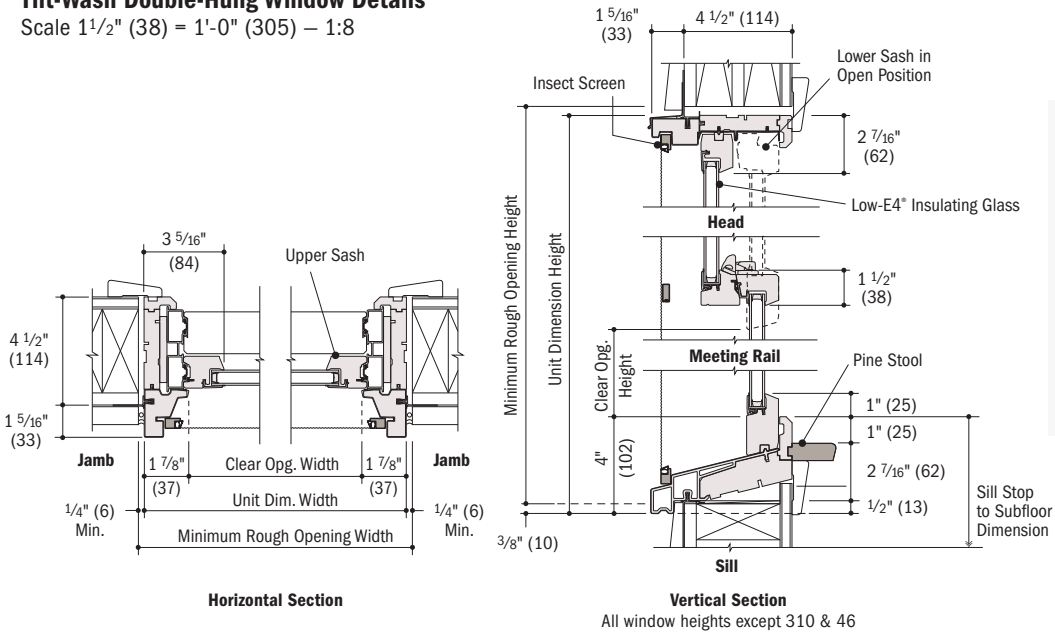

Tilt-Wash Double-Hung Window Details

Scale 1 1/2" (38) = 1'-0" (305) – 1:8



310 and 46 Height Windows Only:

Upper Sash Meeting Rail (higher location on 310 and 46 heights)

Lower Sash in Open Position (opens higher to maintain clear opening)

Meeting Rail

Note: Location of support bar on optional insect screen aligns with meeting rail location on 310 and 46 window heights.

Tilt-Wash Picture Window Details

Scale 1 1/2" (38) = 1'-0" (305) – 1:8

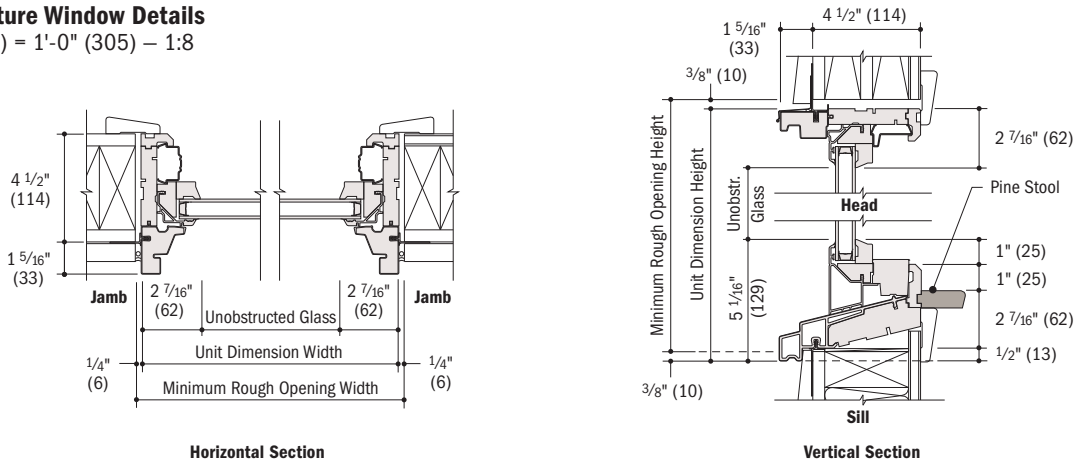

Tilt-Wash Transom Window Details

Scale 1 1/2" (38) = 1'-0" (305) – 1:8

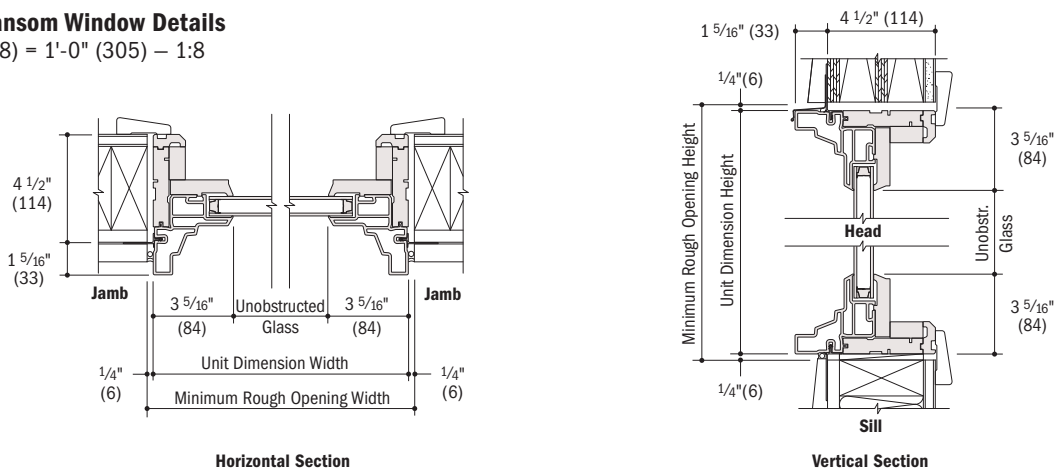

- Light-colored areas are parts included with window. Dark-colored areas are additional Andersen® parts required to complete window assembly as shown.
- **Minimum rough openings may need to be increased to allow for use of building wraps, flashing, sill panning, brackets, fasteners or other items.**
- Details are for illustration only and are not intended to represent product installation methods or materials. Refer to product installation guides at andersenwindows.com.
- Dimensions in parentheses are in millimeters.